

state machine Pausing [ Pausing ]

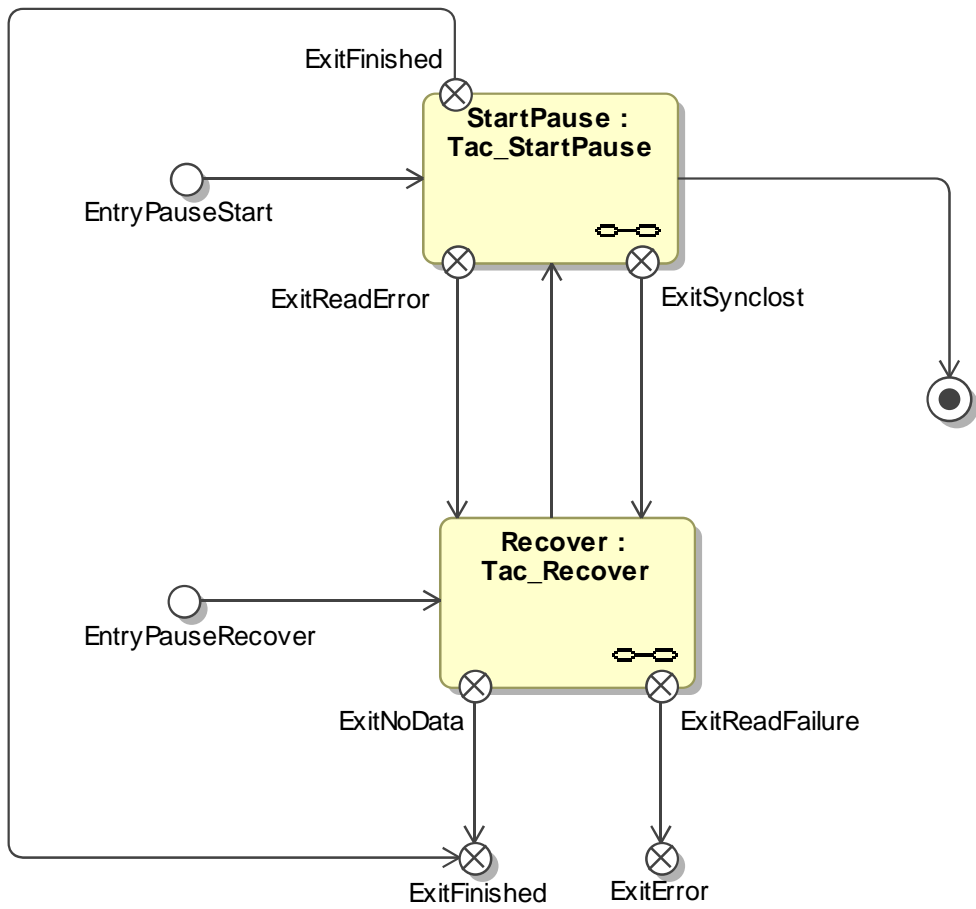

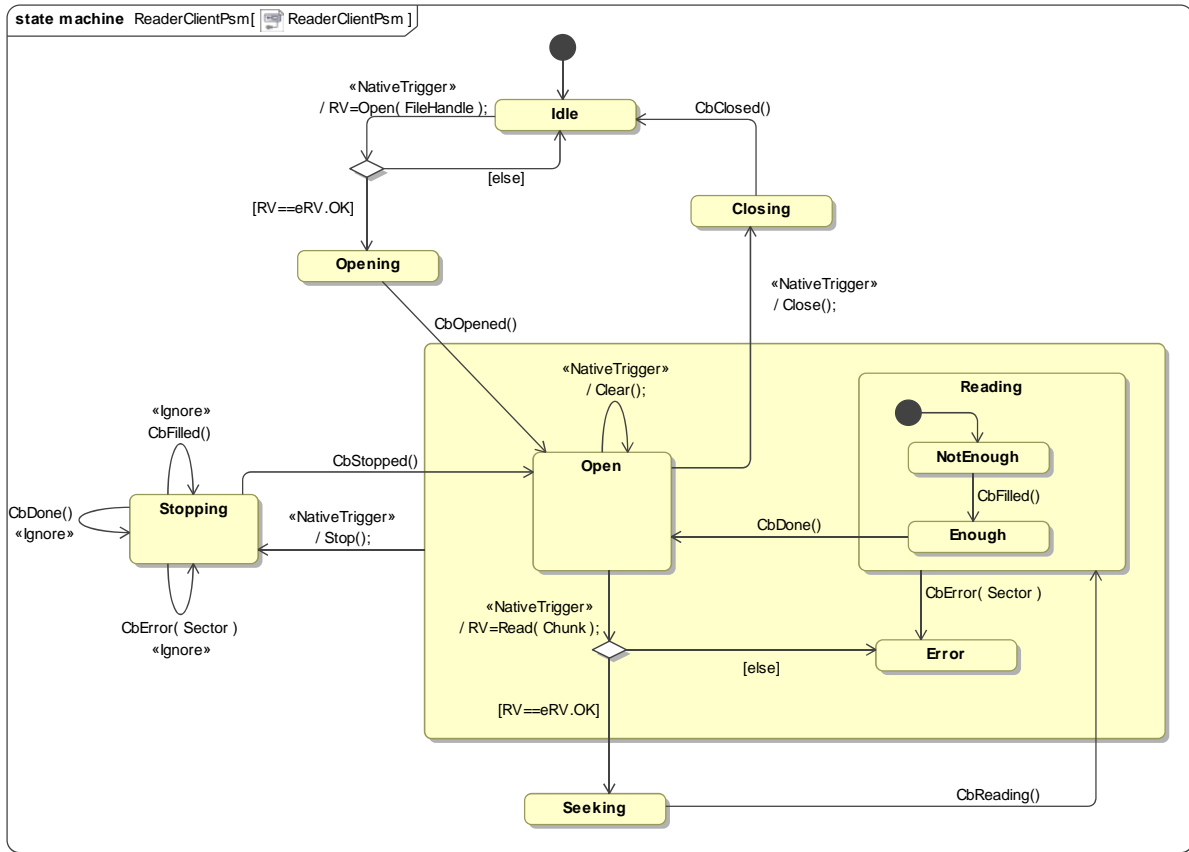

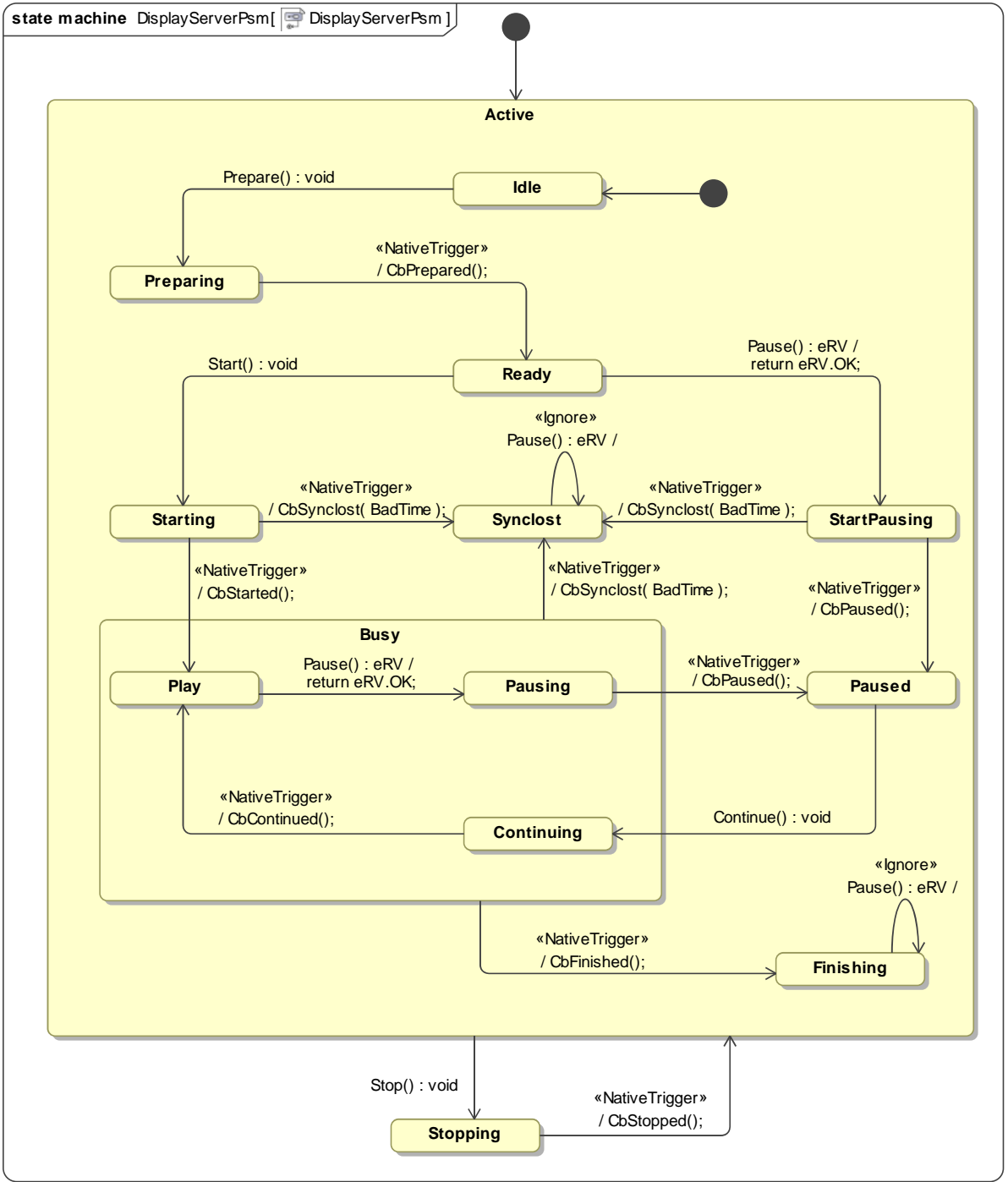

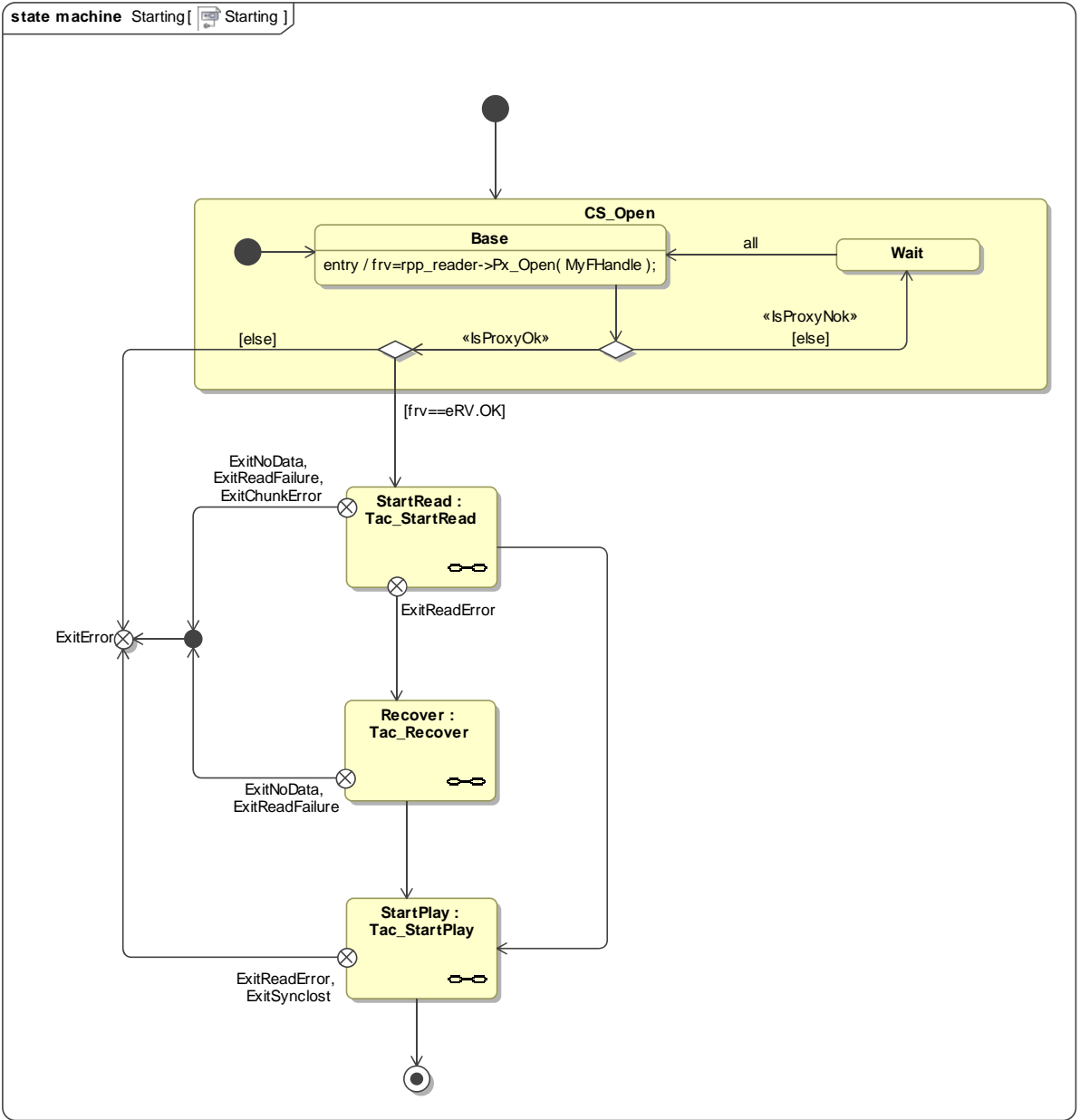

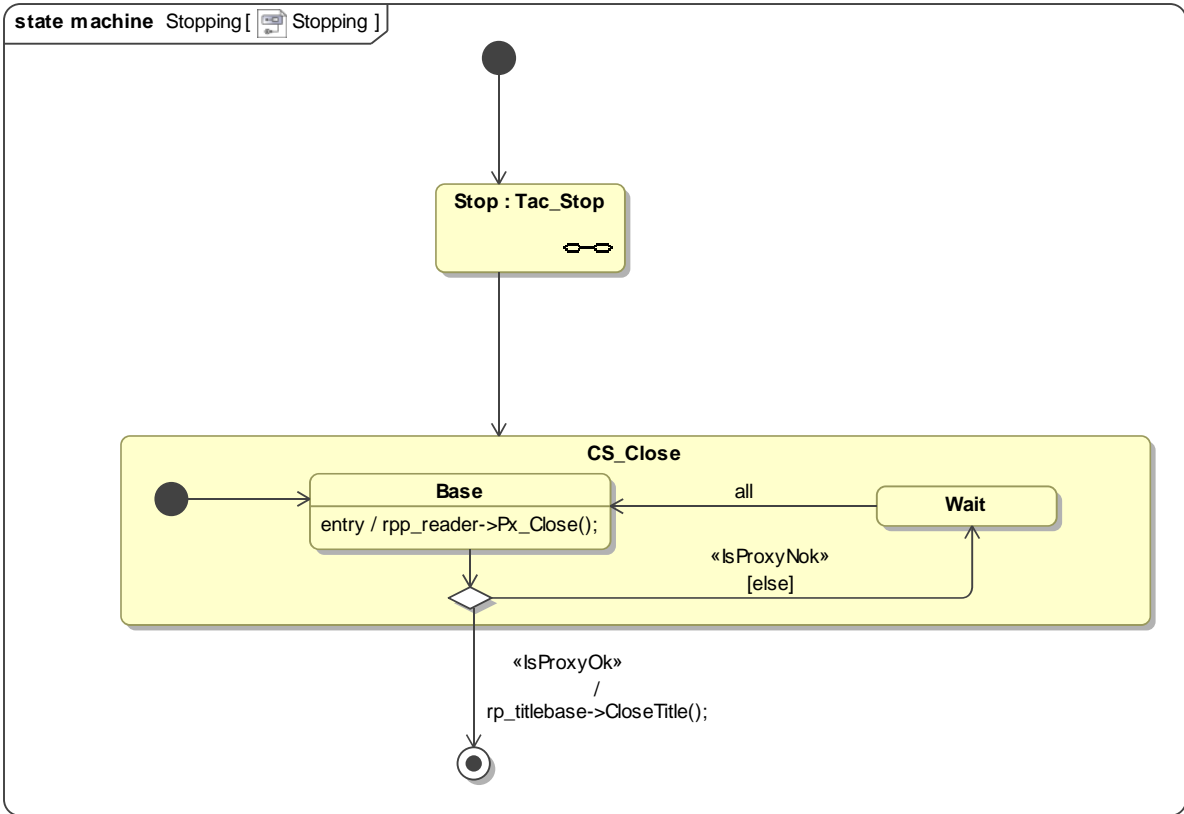

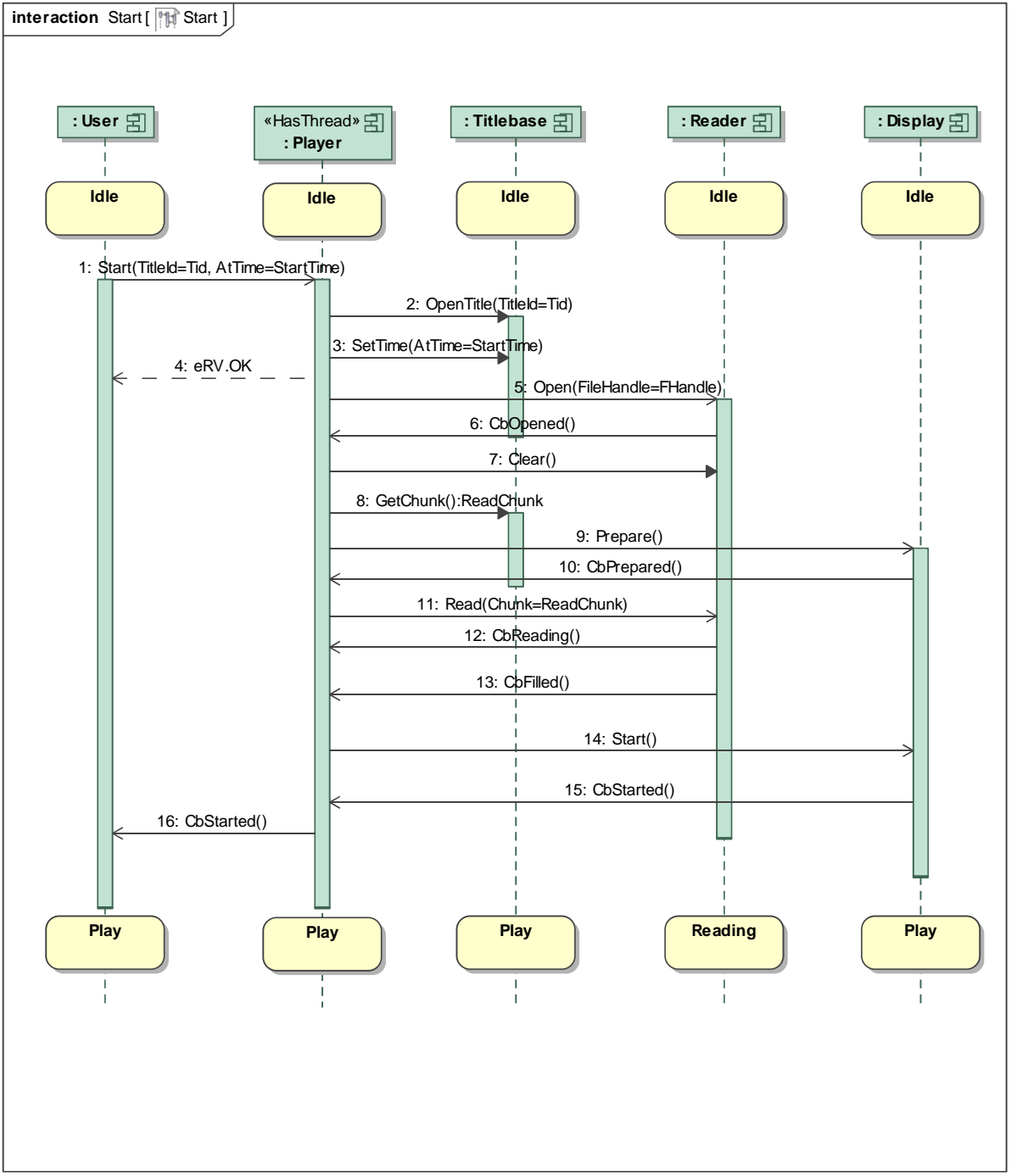

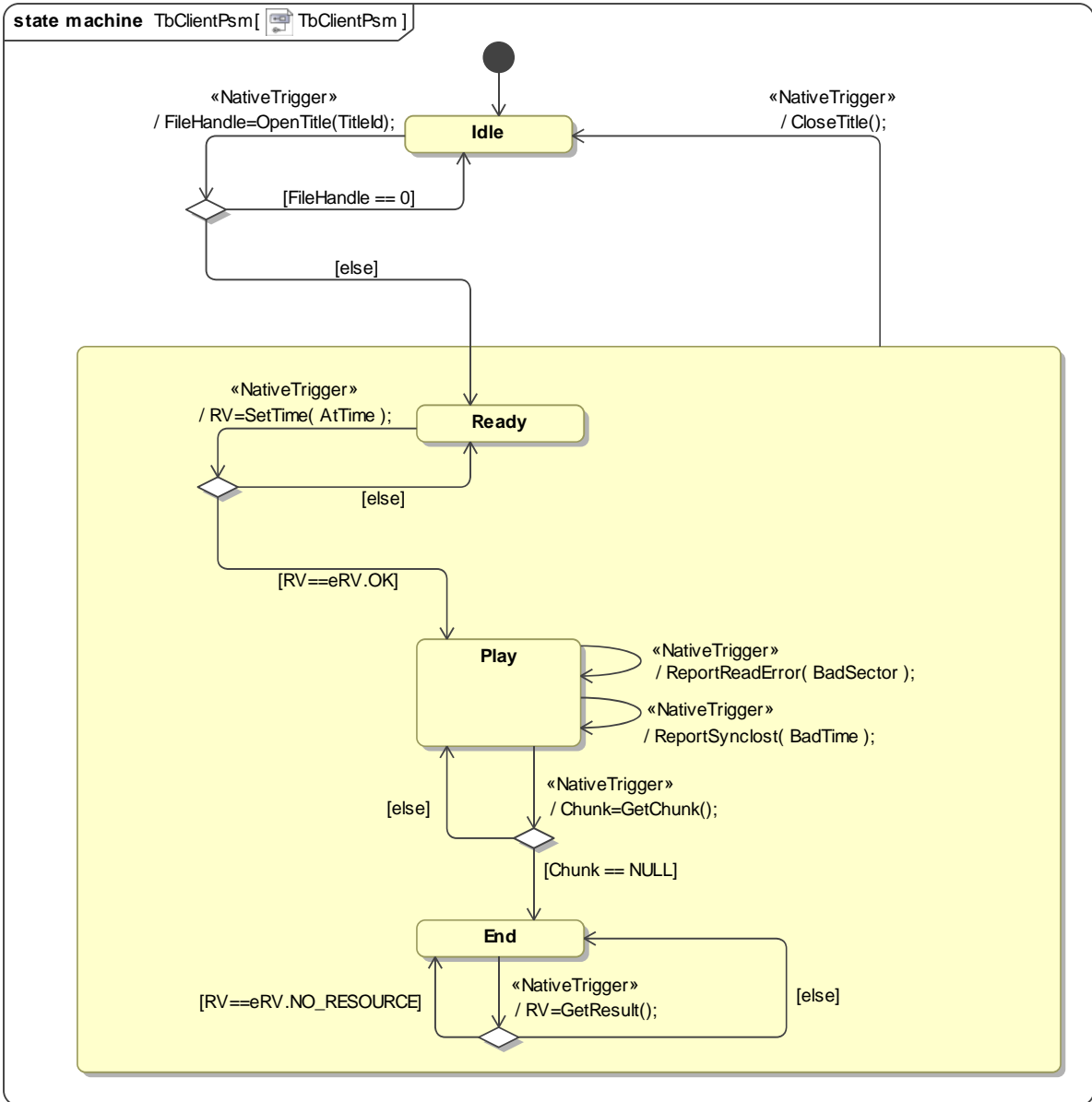



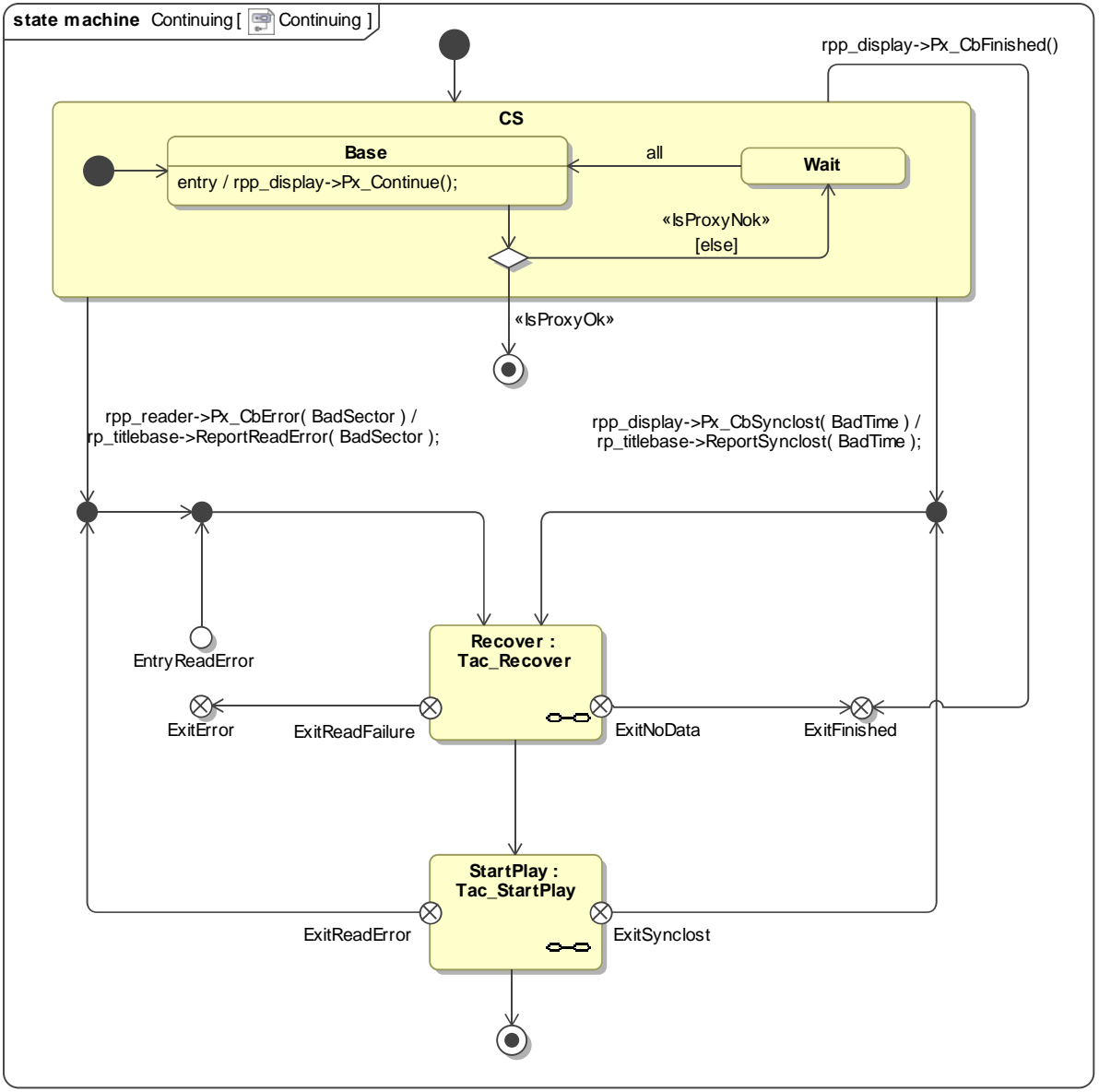

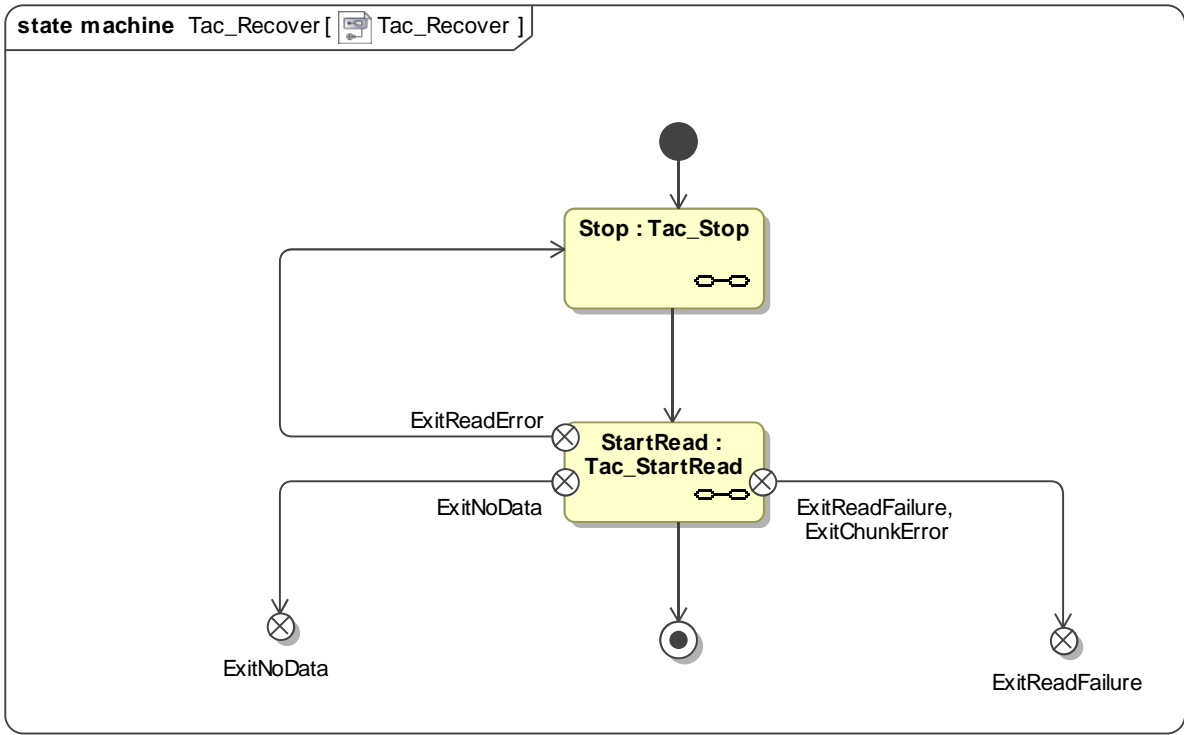

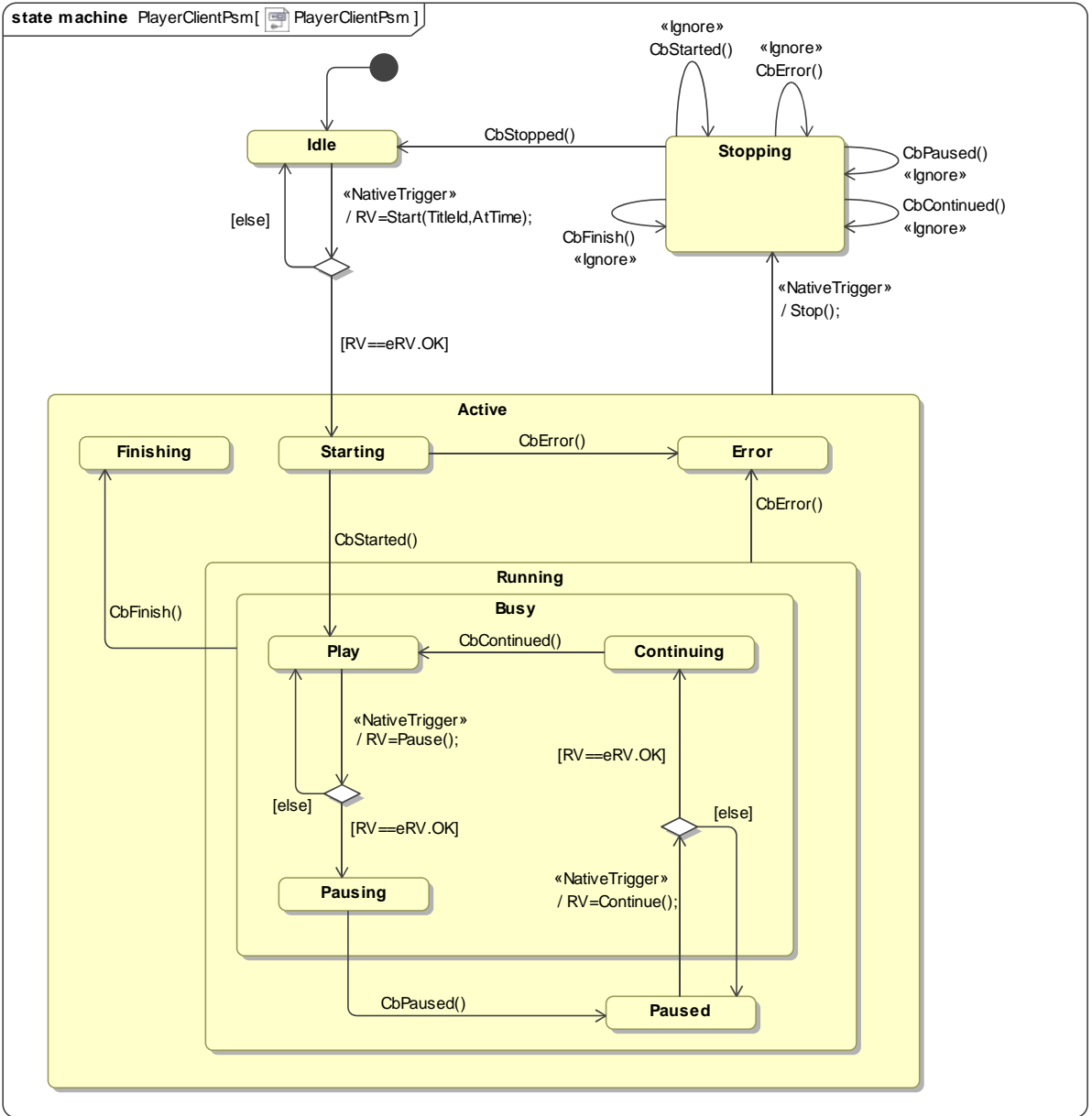

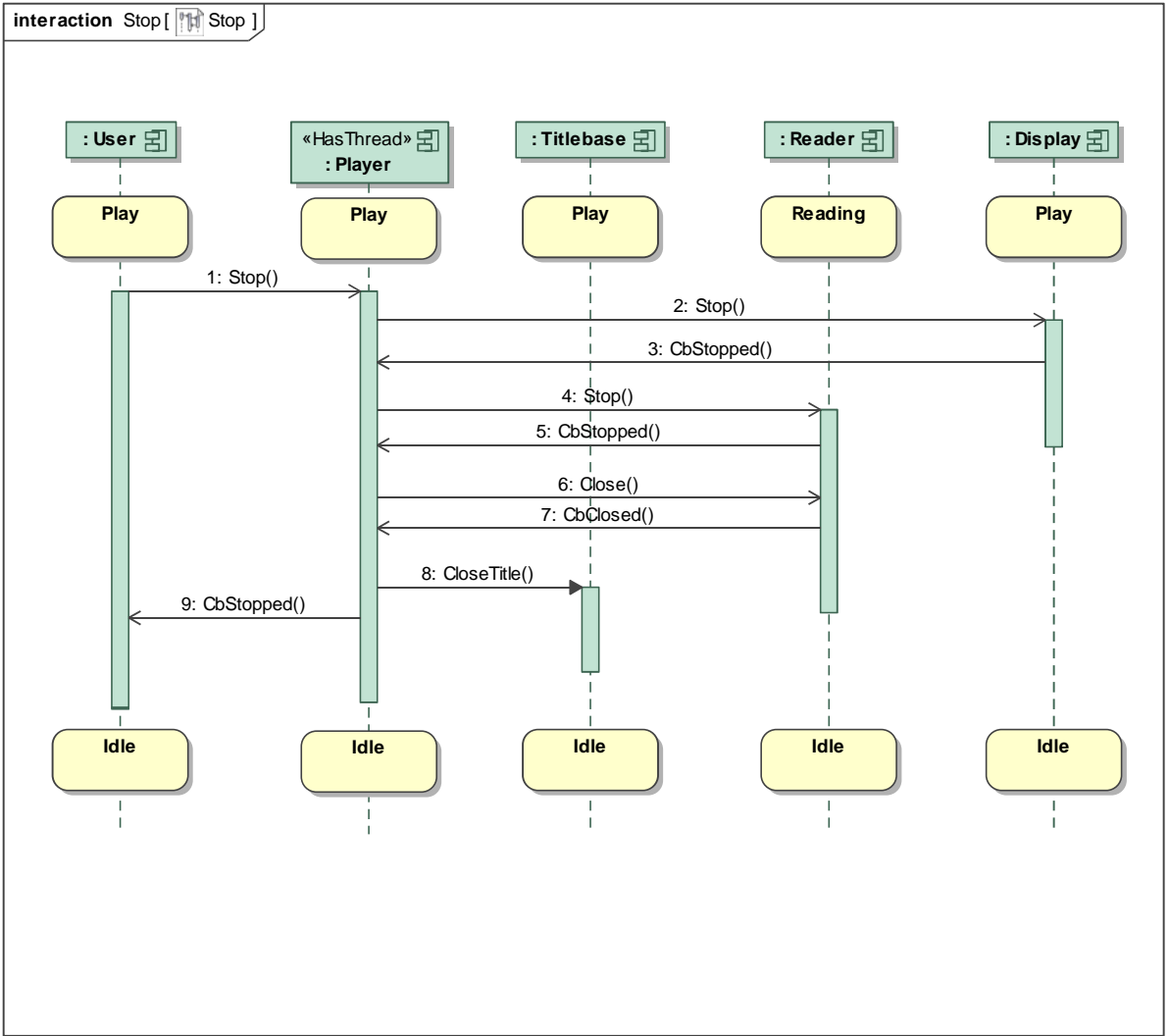

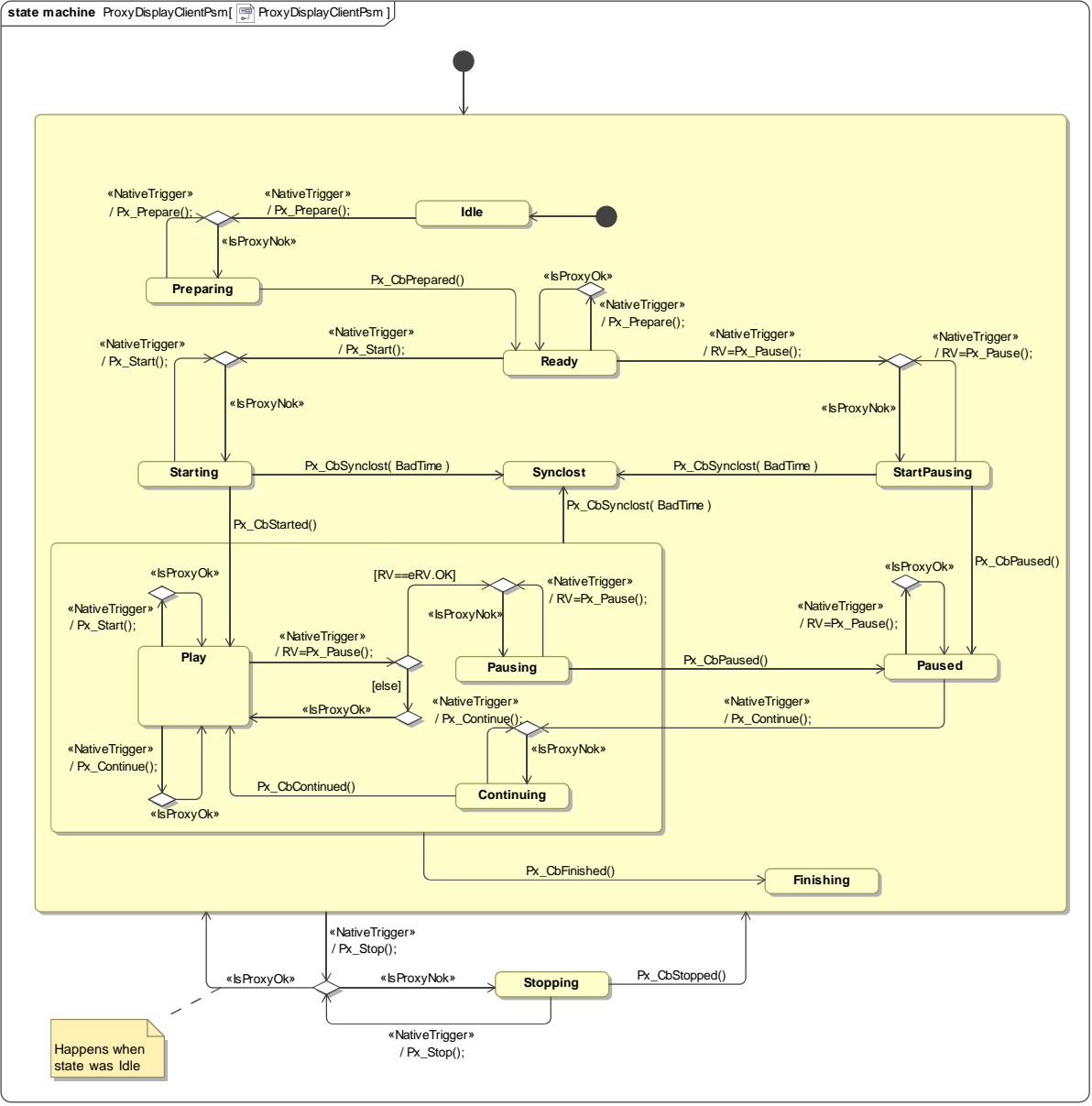

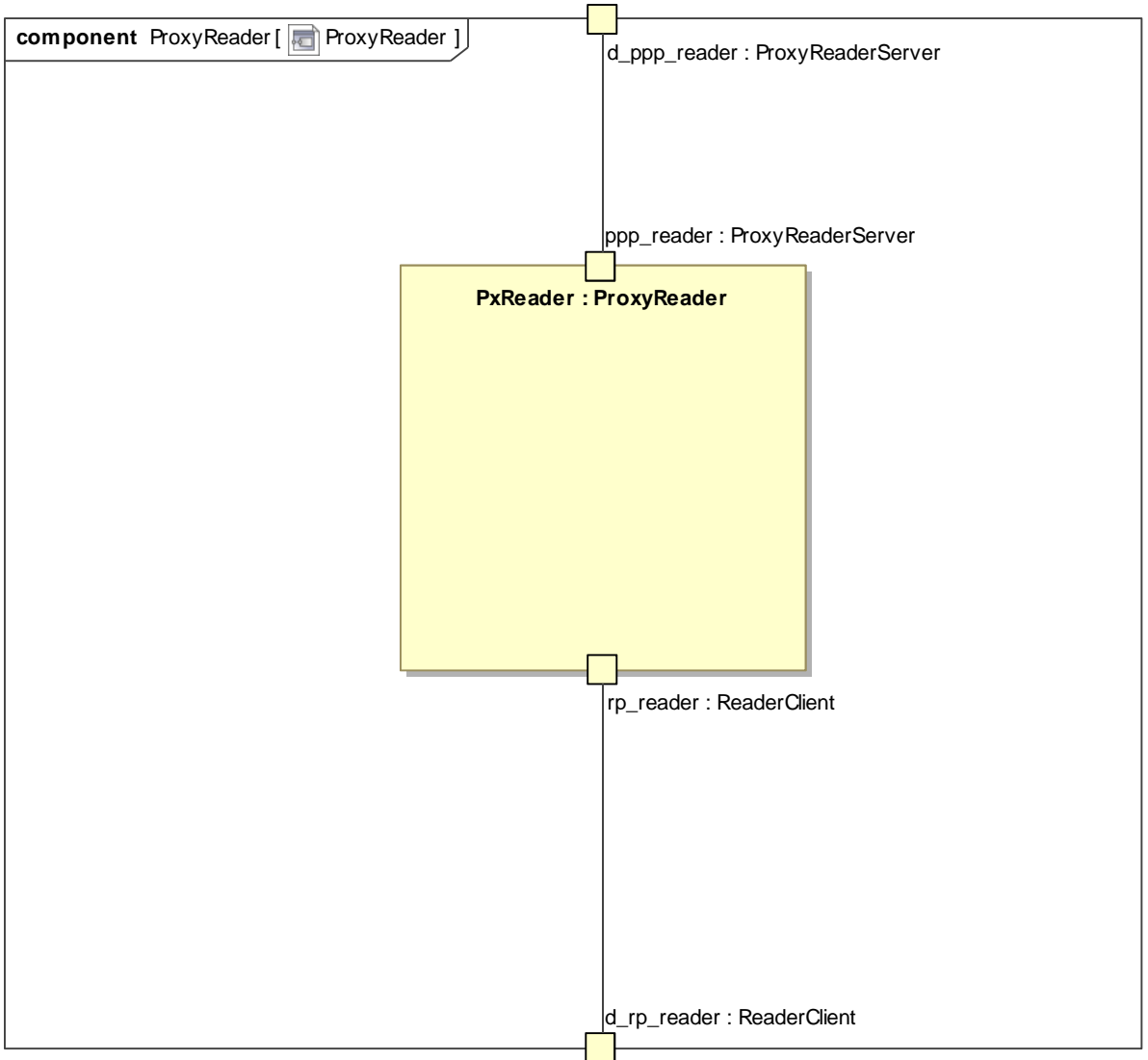

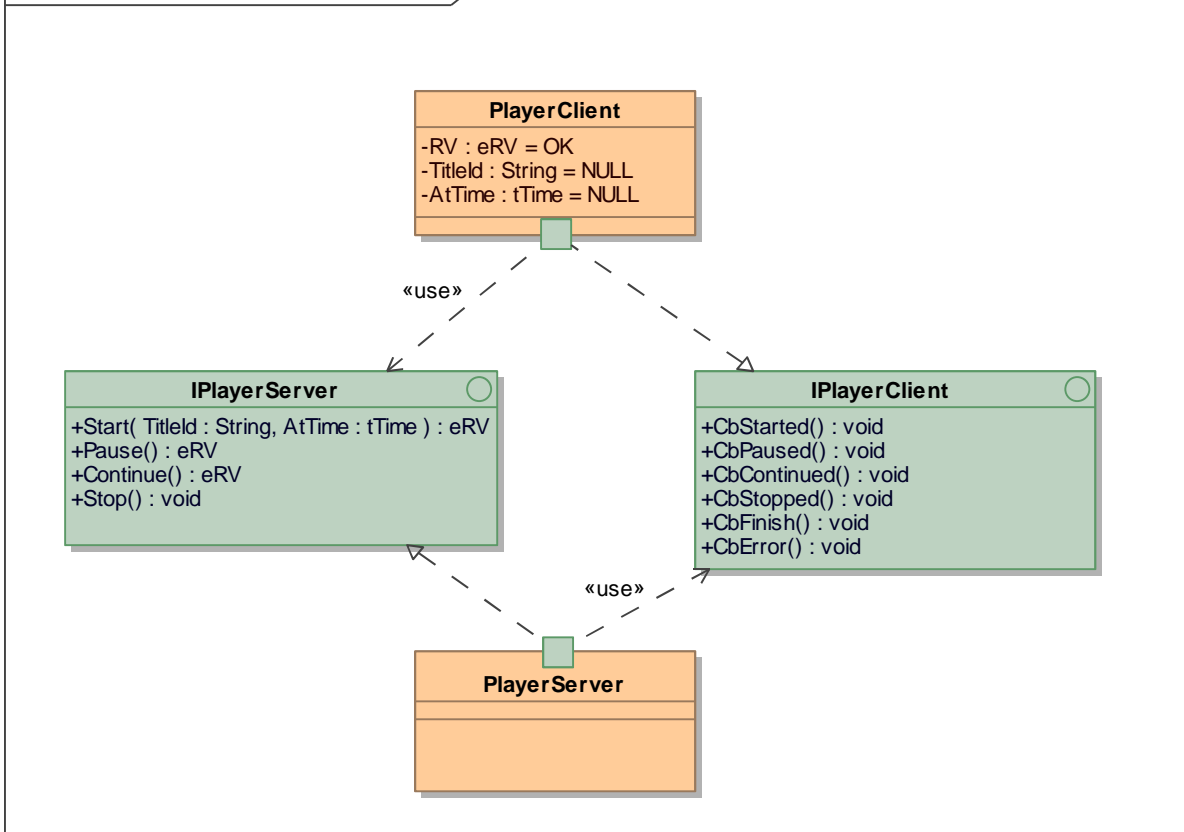

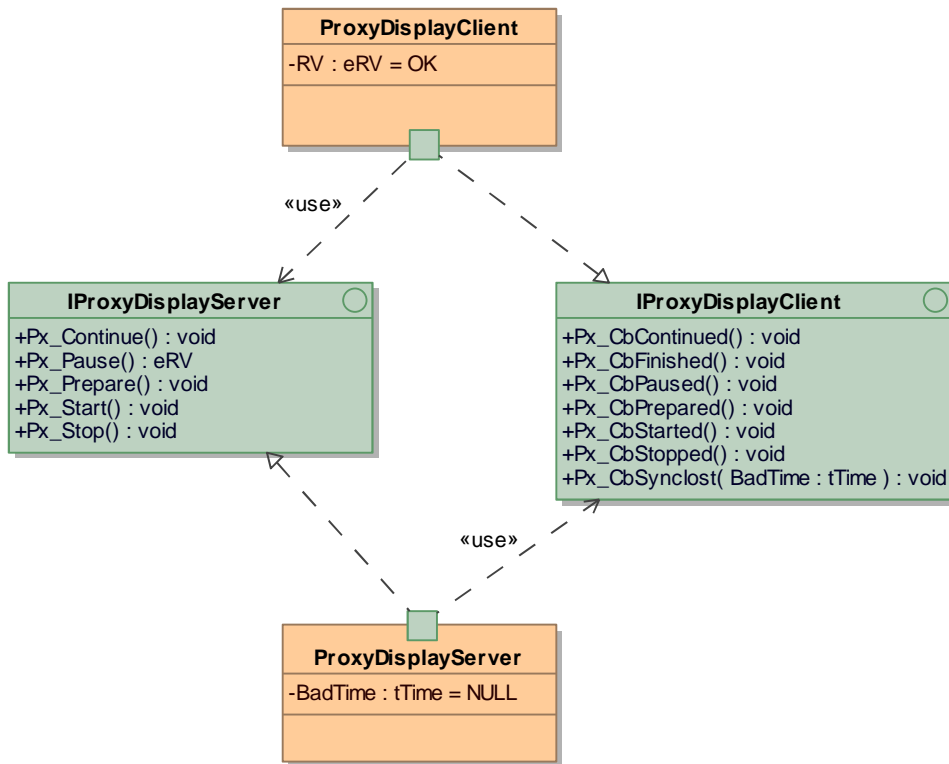



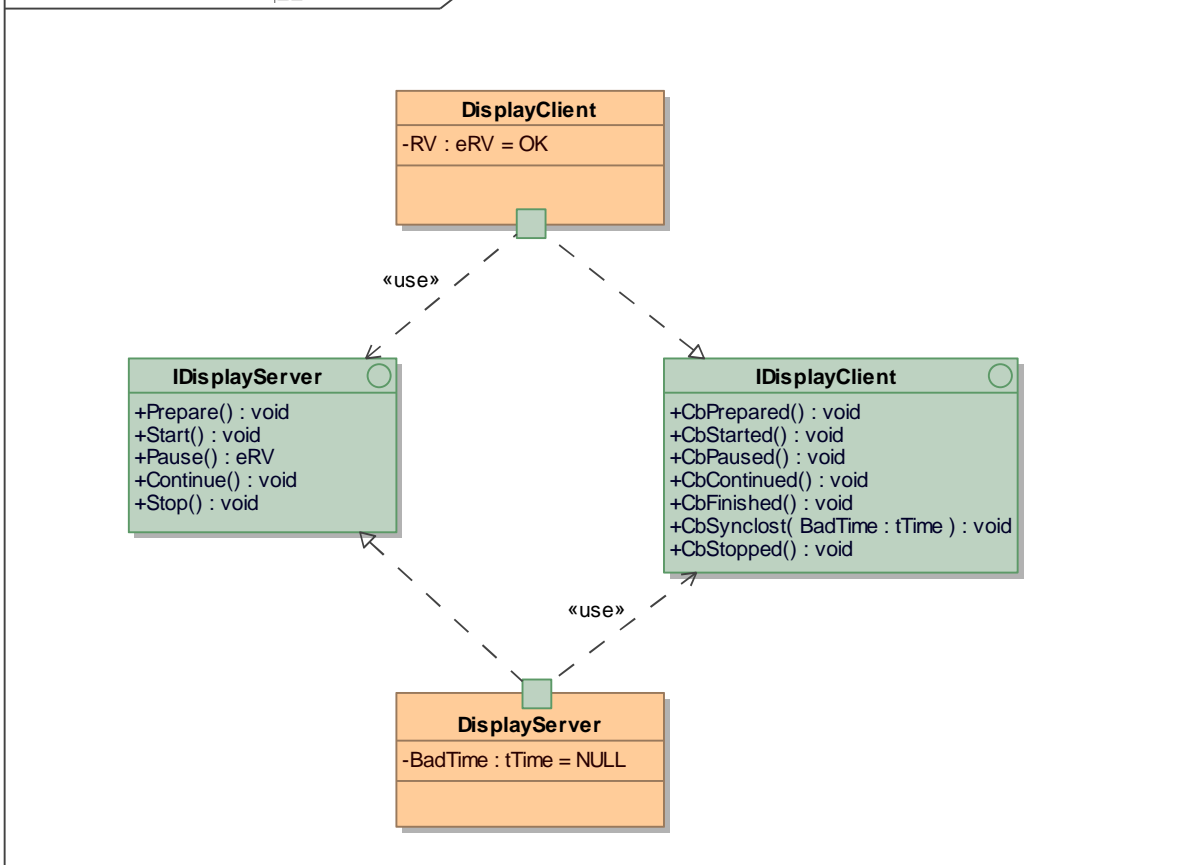

state machine Tac\_StartPause [ Tac\_StartPause ]

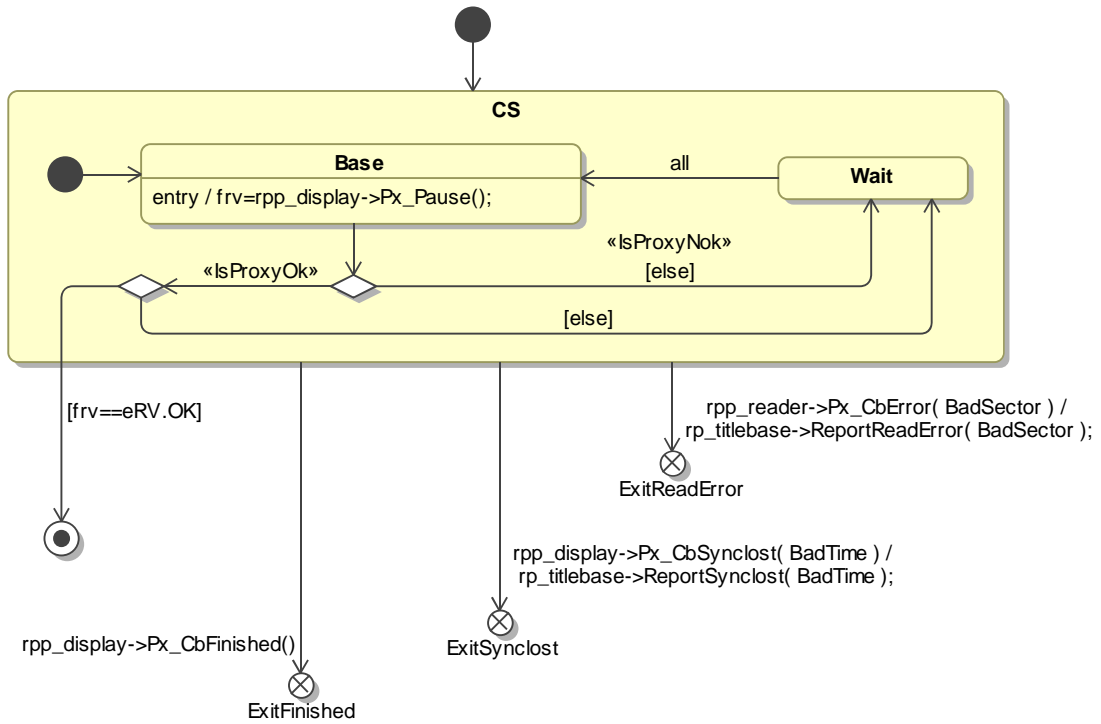

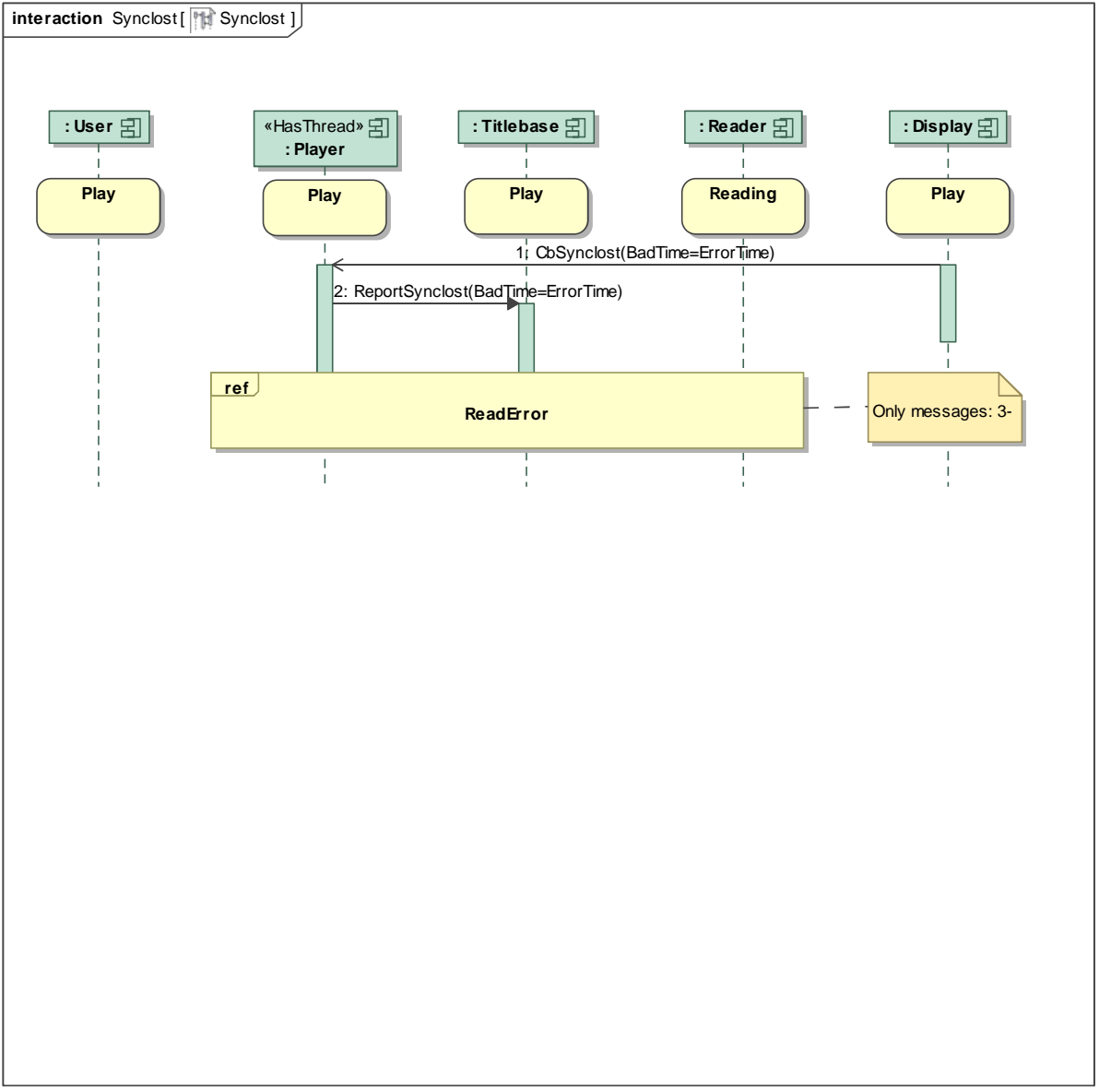

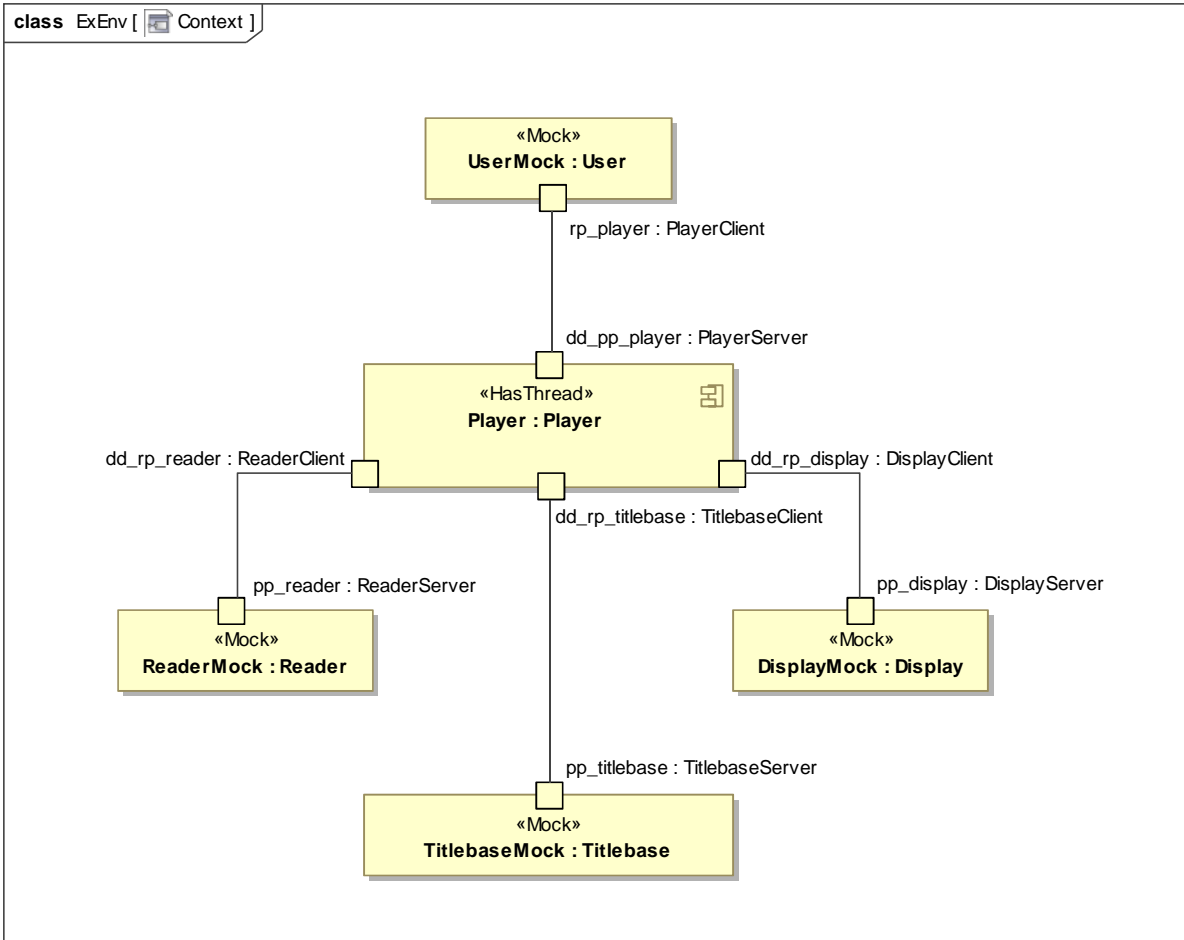

state machine Tac\_StartPlay [ Tac\_StartPlay ]

